

PRELIMINARY



119 kW (Tier 3a)

129 kW (Tier 4)



50 t



30.4 m



MAX CAB

653E

Telescopic crawler crane

Tier 4 emission standards

653E Technical data, equipment

MACHINE TYPE

Model (type) **653**

ENGINE

Model	Cummins QSB 4.5 diesel motor, 119 kW/162 hp at 2,200 rpm Tier 3a emission standard
	Cummins QSB 4.5 diesel motor, 129 kW/175 hp at 2,500 rpm Tier 4f emission standard
	Direct injection, turbo-charged, charge air cooling, reduced emissions
Cooling	Water-cooled
Diesel filter	With water separator and heating system
Air filter	Dry filter with integrated pre-separator, automatic dust discharge, main element and safety element, contamination indicator
Fuel tank	360 l
AdBlue tank	38 l
Electrical system Anlage	24 V
Batteries	2 x 155 AH battery disconnect switch
Options	<ul style="list-style-type: none"> ■ Low-temperature package with engine pre-heating and heated diesel filter for temperatures below -20 °C ■ Electric fuel pump

UPPERCARRIAGE

Design	Torsion-resistant box design, precision crafted, steel bushings for boom bearings. Extremely service-friendly design, longitudinal engine
Electrical system	Central electrical distributor, battery disconnect switch
Cooling system	3-circuit cooling system with high cooling capacity, electronically regulated fan drive for water, charge air and oil cooler
Safety	Rearview and right sideview cameras, LED lighting package
Options	<ul style="list-style-type: none"> ■ Additional LED headlights ■ Up to 2 additional cameras ■ Anti-corrosive maritime climate varnish ■ Low-temperature package for use at temperatures below -20 °C

Options

- Automatic central lubrication for boom pivot point, luffing cylinder, slewing ring track and winch drum bearing
- Pinion tooth lubrication for slewing ring
- Upper-carriage railing

HYDRAULIC SYSTEM

	Load sensing/LUDV hydraulic system, electrohydraulic pilot-controlled work functions, load limit sensing control
Pump type	Swashplate-type variable-displacement piston pump, load pressure-independent flow distribution for simultaneous, independent control of work functions
Pump control	Zero-stroke control, on-demand flow control – the pumps only pump as much oil as will actually be used, pressure purging, load limit sensing control
Operating pressure	max. 330 bar
Filtration	High-performance filtration with long change interval
Hydraulic tank	500 l
Control system	Proportional, precision electrohydraulic actuation of work movements, 2 electric servo joysticks for work functions, including winch motion display via vibration transducer, additional functions via switches and pedals
Safety	Hydraulic circuits secured with safety valves Pipe fracture safety valve for luffing and telescoping cylinders
Options	<ul style="list-style-type: none"> ■ Bio-oil – environmentally friendly ■ SENNEBOGEN HydroClean 3-µm hydraulic microfilter ■ Electric heater for hydraulic tank for temperatures below -20 °C

SLEWING DRIVE

Gearbox	Compact planetary gear with slant-axis hydraulic motor, integrated brake valves
Slewing gear brake	Spring-loaded disk brake, pedal for individual braking
Slewing ring	Externally geared slewing ring, sealed
Slewing speed	0 – 2 rpm, variable

653E Technical data, equipment

CAB MAX CR3

Cab type	maXcab full-size cab, 15° tiltable
Cab equipment	Sliding door, excellent ergonomics, automatic climate control, heated seat, air-suspension comfort seat, fresh air filter/circulating air filter, 12/24 V connections, SENCON, roller shade for sunroof
Options	<ul style="list-style-type: none"> ■ Hydraulically elevating cab E270, can be elevated 2.70 m and tilted 30° ■ Auxiliary heating system with timer ■ Activated-carbon filter for cab ■ Sliding window in operator door ■ Armored-glass windshield ■ Armored-glass sunroof ■ Protective roof grating ■ FOPS protective roof grating ■ Radio with CD player

ATTACHMENTS

Design	Decades of experience, state-of-the-art computer simulation, maximum stability, longest service life, oversized, low-maintenance bearing points, sealed special bearing bushes, precision-crafted
Telescopic boom	4-piece with pulley head, continuous hydraulic telescoping from 9.4 – 30.4 m
Hoisting winch	Slant-axis hydraulic motor drive with compact planetary gear, 50 kN pulling power (4th layer), 0 - 115 m/min. cable speed, 16 mm cable diameter, 170 m cable length. Winch motion display via vibration transducers in the joysticks
Safety brake	Spring-loaded disk brake
Crane safety	Next-generation load moment monitoring, straightforward panel displaying all important data through SENCON display, lifting limit switch, cable exit protection, pressure relief valves and pipe fracture safety device with event recorder
Cylinders	Hydraulic cylinders with high-quality sealing and guide elements
Options	<ul style="list-style-type: none"> ■ 6.5-m fly boom, tiltable (0°, 40°), extremely fast and easy setup without auxiliary devices, locked on basic boom when not in use ■ Fly boom extension to 13 m, tiltable (0°, 40°)

Options	<ul style="list-style-type: none"> ■ Auxiliary jib, 5-t load capacity, 1-strand ■ 2nd crane winch with 50 kN pulling power (4th layer), 0 - 115 m/min. cable speed, 16 mm cable diameter and 170 m cable length ■ Additional load charts accepted for 2°/4° incline position ■ Suitable for use as elevating work platform with up to 4 m width and 500 kg payload ■ 3-kW electrohydraulic emergency unit ■ Remote radio control
---------	--

UNDERCARRIAGE

Design	T41/380 crawler undercarriage with hydraulically extendable track width. Stable welded construction.
Drive	Hydraulic travel drive for each running gear side, variable displacement hydraulic travel motors
Parking brake	Spring-loaded, hydraulically ventilated disk brake
Traveling gear	700-mm 3-grouser crawler shoes, maintenance-free tractor chassis
Speed	0 - 2.9 kph
Options	Available crawler shoe types: <ul style="list-style-type: none"> ■ 800-mm triple-bar-shoes ■ 900-mm triple-bar-shoes ■ 700-mm flat crawler shoes

OPERATING WEIGHT

Mass	<p>Approx. 50,200 kg</p> <p>With 30.4-m telescopic boom, 13-m fly boom, 35-t hook, 700-mm 3-grouser crawler shoes, 2 hoisting winches, hydraulically telescoping undercarriage, 8.9-t ballast, 5.5-t undercarriage ballast</p>
Note	The operating weight varies according to model type.

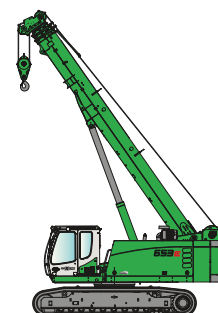

653E Crane equipment



30.4-m main boom (HA)

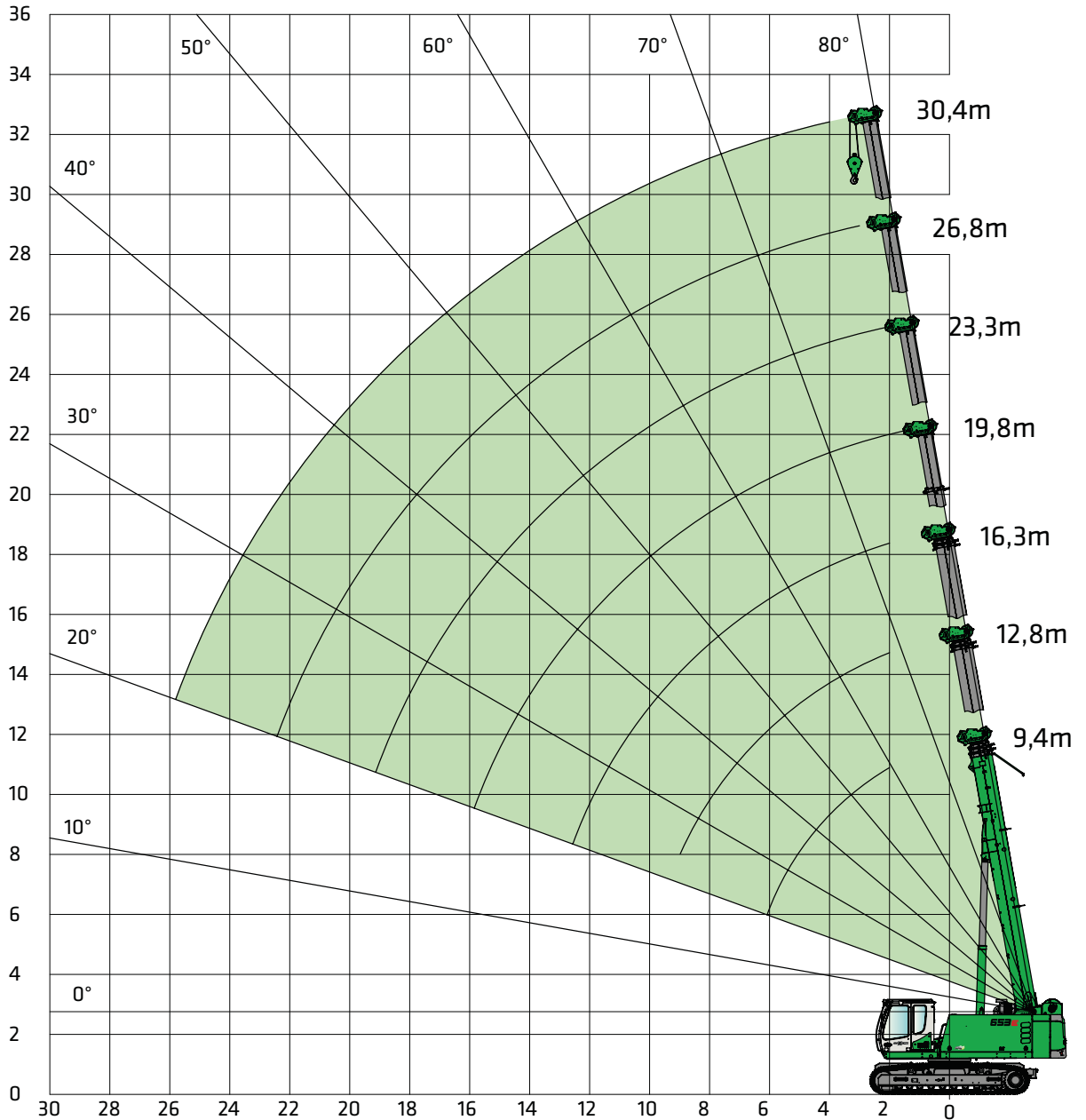

Hook

Capacity	Weight	Rope reeving and max. load capacity										
		10	9	8	7	6	5	4	3	2	1	
5 t	80 kg											5,000 kg
15 t 1-pulley	190 kg								15,000 kg	10,000 kg	5,000 kg	
35 t 3-pulley	260 kg				35,000 kg	30,000 kg	25,000 kg	20,000 kg	15,000 kg	10,000 kg	5,000 kg	
60 t 6-pulley	540 kg	50,000 kg	45,000 kg	40,000 kg	35,000 kg	30,000 kg	25,000 kg	20,000 kg	15,000 kg	10,000 kg	5,000 kg	

653E Load ratings



30.4-m main boom (HA)

	Boom length [m]																					
	9.4			12.8			16.3			19.8			23.3			26.8			30.4			
Counterweight [t]	8.9	8.9	8.9	8.9	8.9	8.9	8.9	8.9	8.9	8.9	8.9	8.9	8.9	8.9	8.9	8.9	8.9	8.9	8.9	8.9	8.9	
Carbody counterweight [t]	5.5	5.5	5.5	5.5	5.5	5.5	5.5	5.5	5.5	5.5	5.5	5.5	5.5	5.5	5.5	5.5	5.5	5.5	5.5	5.5	5.5	
Undercarriage track width [m]	3.8	3.0	2.3	3.8	3.0	2.3	3.8	3.0	2.3	3.8	3.0	2.3	3.8	3.0	2.3	3.8	3.0	2.3	3.8	3.0	2.3	
Outreach [m]																						
2.0	50.0	40.0		31.0	31.0		26.0	26.0		15.6	15.6		14.5	14.5								
3.0	45.0	40.0		31.0	31.0		24.4	24.4		15.6	15.6		14.5	14.5		12.7	12.7					
4.0	38.0	30.0	24.0	31.0	30.0	22.7	21.7	21.7	20.0	15.6	15.6	15.6	14.5	14.5	14.5	12.6	12.6	12.6	9.2	9.2	9.2	
5.0	30.0	22.5	17.0	28.0	22.6	17.3	19.3	19.3	16.0	15.6	15.6	15.5	14.2	14.2	14.2	12.4	12.4	12.4	9.2	9.2	9.2	
6.0	22.0	17.0	13.0	22.3	17.0	13.2	16.9	16.6	12.8	14.9	14.9	12.6	13.6	13.6	12.3	11.9	11.9	11.9	9.2	9.2	9.2	
7.0				17.3	13.4	10.4	15.0	13.3	10.3	13.6	13.4	10.4	12.5	12.5	10.2	11.1	11.1	10.0	9.1	9.1	9.1	
8.0				14.2	10.9	8.4	13.3	10.8	8.3	12.2	11.2	8.7	11.2	11.2	8.7	10.3	10.3	8.6	8.7	8.7	8.4	
9.0				11.5	9.0	7.0	11.5	8.9	6.9	11.1	9.3	7.3	10.2	9.6	7.5	9.4	9.4	7.4	8.2	8.2	7.3	
10.0							9.7	7.5	5.8	9.9	7.9	6.1	9.3	8.2	6.4	8.6	8.3	6.4	7.8	7.8	6.4	
11.0							8.3	6.4	4.9	8.7	6.8	5.2	8.5	7.0	5.5	8.0	7.2	5.6	7.3	7.3	5.6	
12.0							7.2	5.5	4.1	7.5	5.9	4.5	7.7	6.1	4.7	7.3	6.3	4.9	6.8	6.4	5.0	
13.0							6.2	4.7	3.5	6.6	5.1	3.9	6.9	5.4	4.1	6.8	5.5	4.3	6.4	5.7	4.4	
14.0										5.8	4.5	3.4	6.0	4.7	3.6	6.1	4.9	3.8	5.9	5.0	3.9	
15.0										5.2	3.9	2.9	5.4	4.2	3.2	5.6	4.4	3.3	5.6	4.5	3.5	
16.0										4.6	3.5	2.5	4.8	3.7	2.8	5.0	3.9	2.9	5.0	4.0	3.1	
17.0													4.3	3.3	2.4	4.5	3.5	2.6	4.7	3.6	2.7	
18.0													3.9	2.9	2.1	4.1	3.1	2.3	4.2	3.2	2.4	
19.0													3.5	2.6	1.8	3.7	2.8	2.0	3.9	2.9	2.1	
20.0													3.1	2.3	1.5	3.4	2.5	1.7	3.5	2.6	1.9	
21.0																3.1	2.2	1.5	3.2	2.4	1.6	
22.0																2.8	2.0	1.3	2.9	2.1	1.4	
23.0																2.5	1.8	1.1	2.7	1.9	1.2	
24.0																			2.4	1.7	1.1	
25.0	Table no.: 653R-75/1977/8.9+5.5/10.14 HA 0,3°																					
26.0	Table no.: 653R-75/1577/8.9+5.5/10.14 HA 0,3°																					
	Table no.: 653R-75/1227/8.9+5.5/10.14 HA 0,3°																					
Parts reeving	4	10	10	3	8	8	3	6	6	2	4	4	2	4	4	2	4	4	1	4	4	
I	0%			50%			100%			100%			100%			100%			100%			
II	0%			0%			0%			25%			50%			75%			100%			
III	0%			0%			0%			25%			50%			75%			0%			
<i>Reduction of load</i>	580			420			330			270			230			200			180			

653E Crane equipment



6.5-m or 13-m fly jib (SA)

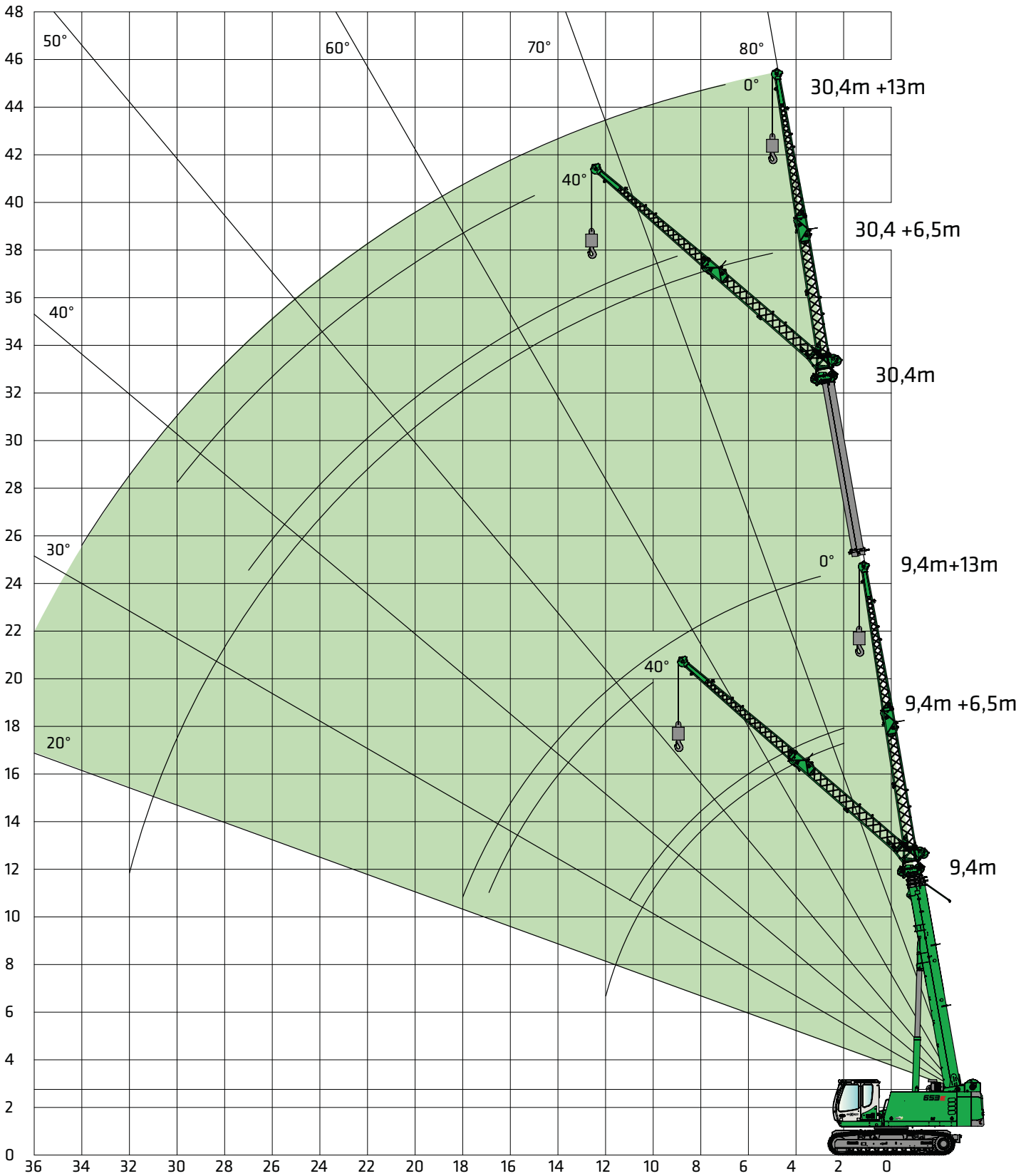

653E Load ratings



6.5-m fly jib (SA)

8.9 t	5.5 t	Telescopic boom length [m]							
		9.4		16.3		23.8		30.3	
3.8 m		0°	40°	0°	40°	0°	40°	0°	40°
Working radius [m]									
2.0		10.0							
3.0		9.9		10.0		9.9			
4.0		8.6		9.9		9.4			
5.0		7.7	4.6	9.4		9.0		4.9	
6.0		6.9	4.4	8.7	4.6	8.5		4.8	
7.0		6.3	4.2	8.0	4.5	8.0	4.4	4.8	
8.0		5.7	4.0	7.4	4.3	7.6	4.3	4.7	
9.0		5.2	3.9	6.9	4.2	7.2	4.2	4.7	4.0
10.0		4.8	3.8	6.4	4.1	6.8	4.1	4.7	4.0
11.0		4.5	3.7	6.0	4.0	6.5	4.0	4.7	3.9
12.0		4.1		5.7	3.9	6.2	3.9	4.7	3.8
13.0				5.3	3.8	5.9	3.9	4.6	3.8
14.0				5.0	3.8	5.7	3.8	4.4	3.7
15.0				4.8	3.7	5.4	3.7	4.2	3.7
16.0				4.6	3.7	5.0	3.7	4.0	3.6
17.0				4.2		4.6	3.6	3.8	3.5
18.0				4.0		4.2	3.6	3.7	3.4
19.0						3.7	3.6	3.5	3.3
20.0						3.5	3.5	3.4	3.2
21.0						3.2	3.3	3.2	3.1
22.0						2.9		3.0	3.0
23.0						2.6		2.7	2.8
24.0						2.4		2.4	2.6
25.0								2.2	2.4
26.0								2.0	2.2
27.0								1.8	2.0
28.0								1.7	
29.0								1.5	
30.0								1.4	
31.0								1.2	
32.0								1.1	
33.0									
34.0									
Parts reeving		2	1	2	1	2	1	2	1
I		0%		100%		100%		100%	
II		0%		0%		50%		100%	
III		0%		0%		50%		100%	

Table no.: 653R-75/1977/8.9 t + 5.5/10.14 SA6.5 0.3°

653E Load ratings



13-m fly jib (SA)

	8.9 t	5.5 t	Telescopic boom length [m]							
			9.4		16.3		23.8		30.3	
			0°	40°	0°	40°	0°	40°	0°	40°
Working radius [m]										
2.0										
3.0	4.6									
4.0	4.4		4.6							
5.0	4.0		4.4			3.8				
6.0	3.7		4.1			3.7				
7.0	3.4		3.8			3.6		2.1		
8.0	3.1		3.6			3.4		2.1		
9.0	2.9		3.4			3.3		2.1		
10.0	2.7	1.8	3.2			3.1		2.1		
11.0	2.5	1.7	3.0			3.0		2.1		
12.0	2.3	1.7	2.8	1.7		2.9		2.1		
13.0	2.2	1.7	2.6	1.7		2.7	1.7	2.1		
14.0	2.0	1.6	2.5	1.7		2.6	1.6	2.1		
15.0	1.9	1.6	2.4	1.6		2.5	1.6	2.1	1.5	
16.0	1.8	1.5	2.3	1.6		2.4	1.6	2.1	1.5	
17.0	1.7	1.5	2.1	1.5		2.3	1.5	2.1	1.5	
18.0	1.6		2.0	1.5		2.2	1.5	2.1	1.5	
19.0			2.0	1.5		2.1	1.5	2.0	1.4	
20.0			1.9	1.5		2.1	1.5	2.0	1.4	
21.0			1.8			2.0	1.4	1.9	1.4	
22.0			1.7			1.9	1.4	1.9	1.4	
23.0			1.6			1.8	1.4	1.8	1.4	
24.0			1.5			1.8	1.4	1.8	1.3	
25.0						1.7	1.4	1.7	1.3	
26.0						1.7	1.4	1.7	1.3	
27.0						1.6		1.6	1.3	
28.0						1.4		1.6	1.3	
29.0						1.4		1.6	1.3	
30.0								1.3	1.1	
31.0								1.1		
32.0								0.9		
33.0	Table no.: 653R-75/1977/8.9+5.5/10.14 SA13 0.3°							0.7		
34.0								0.6		
Parts reeving	2	1	2	1	2	1	2	1		
I	0%		100%		100%		100%			
II	0%		0%		50%		100%			
III	0%		0%		50%		100%			

653E Load ratings



Auxiliary jib (HA-S)

	Boom length [m]																				
	9.4			12.8			16.3			19.8			23.3			26.8			30.4		
Counterweight [t]	8.9			8.9			8.9			8.9			8.9			8.9			8.9		
Carbody counterweight [t]	5.5			5.5			5.5			5.5			5.5			5.5			5.5		
Undercarriage track width [m]	3.8		3.0	2.3		3.8		3.0	2.3	3.8		3.0	2.3	3.8		3.0	2.3	3.8		3.0	2.3
Working radius [m]																					
2.0	5.0	5.0		5.0	5.0		5.0	5.0		5.0	5.0		5.0								
3.0	5.0	5.0		5.0	5.0		5.0	5.0		5.0	5.0		5.0	5.0		5.0					
4.0	5.0	5.0	5.0	5.0	5.0	5.0	5.0	5.0	5.0	5.0	5.0	5.0	5.0	5.0	5.0	5.0	5.0	5.0	5.0	5.0	5.0
5.0	5.0	5.0	5.0	5.0	5.0	5.0	5.0	5.0	5.0	5.0	5.0	5.0	5.0	5.0	5.0	5.0	5.0	5.0	5.0	5.0	5.0
6.0	5.0	5.0	5.0	5.0	5.0	5.0	5.0	5.0	5.0	5.0	5.0	5.0	5.0	5.0	5.0	5.0	5.0	5.0	5.0	5.0	5.0
7.0		5.0	5.0	5.0	5.0	5.0	5.0	5.0	5.0	5.0	5.0	5.0	5.0	5.0	5.0	5.0	5.0	5.0	5.0	5.0	5.0
8.0		5.0	5.0	5.0	5.0	5.0	5.0	5.0	5.0	5.0	5.0	5.0	5.0	5.0	5.0	5.0	5.0	5.0	5.0	5.0	5.0
9.0				5.0	5.0	5.0	5.0	5.0	5.0	5.0	5.0	5.0	5.0	5.0	5.0	5.0	5.0	5.0	5.0	5.0	5.0
10.0				5.0	5.0	5.0	5.0	5.0	5.0	5.0	5.0	5.0	5.0	5.0	5.0	5.0	5.0	5.0	5.0	5.0	5.0
11.0				5.0	5.0	5.0	5.0	5.0	5.0	5.0	5.0	5.0	5.0	5.0	5.0	5.0	5.0	5.0	5.0	5.0	5.0
12.0							5.0	5.0	4.3	5.0	5.0	4.6	5.0	5.0	4.8	5.0	5.0	5.0	5.0	5.0	5.0
13.0							5.0	4.9	3.7	5.0	5.0	4.0	5.0	5.0	4.2	5.0	5.0	4.4	5.0	5.0	4.4
14.0										5.0	4.6	3.5	5.0	4.8	3.7	5.0	5.0	3.8	5.0	5.0	4.0
15.0										5.0	4.0	3.0	5.0	4.3	3.2	5.0	4.4	3.4	5.0	4.5	3.5
16.0										4.5	3.6	2.6	4.7	3.8	2.8	4.9	4.0	3.0	4.9	4.1	3.1
17.0										4.0	3.1	2.2	4.2	3.4	2.5	4.4	3.5	2.6	4.6	3.7	2.8
18.0													3.8	3.0	2.1	4.0	3.2	2.3	4.1	3.3	2.5
19.0													3.4	2.7	1.8	3.6	2.9	2.0	3.8	3.0	2.2
20.0													3.0	2.4	1.6	3.3	2.6	1.8	3.4	2.7	1.9
21.0																3.0	2.3	1.5	3.1	2.4	1.7
22.0																2.7	2.0	1.3	2.8	2.2	1.5
23.0																2.4	1.8	1.1	2.6	1.9	1.3
24.0																	1.6	0.9	2.3	1.7	1.1
25.0	Table no.: 653R-75/1977/8.9+5.5/10.14 HA-S 0.3°																				
26.0	Table no.: 653R-75/1577/8.9+5.5/10.14 HA-S 0.3°																				
26.0	Table no.: 653R-75/1227/8.9+5.5/10.14 HA-S 0.3°																				
Parts reeving	1	1	1	1	1	1	1	1	1	1	1	1	1	1	1	1	1	1	1	1	1
I	0%			50%			100%			100%			100%			100%			100%		
II	0%			0%			0%			25%			50%			75%			100%		
III	0%			0%			0%			25%			50%			75%			0%		
<i>Reduction of load</i>	580			420			330			270			230			200			180		

653E Crane equipment



Elevating work platform type 4000/500

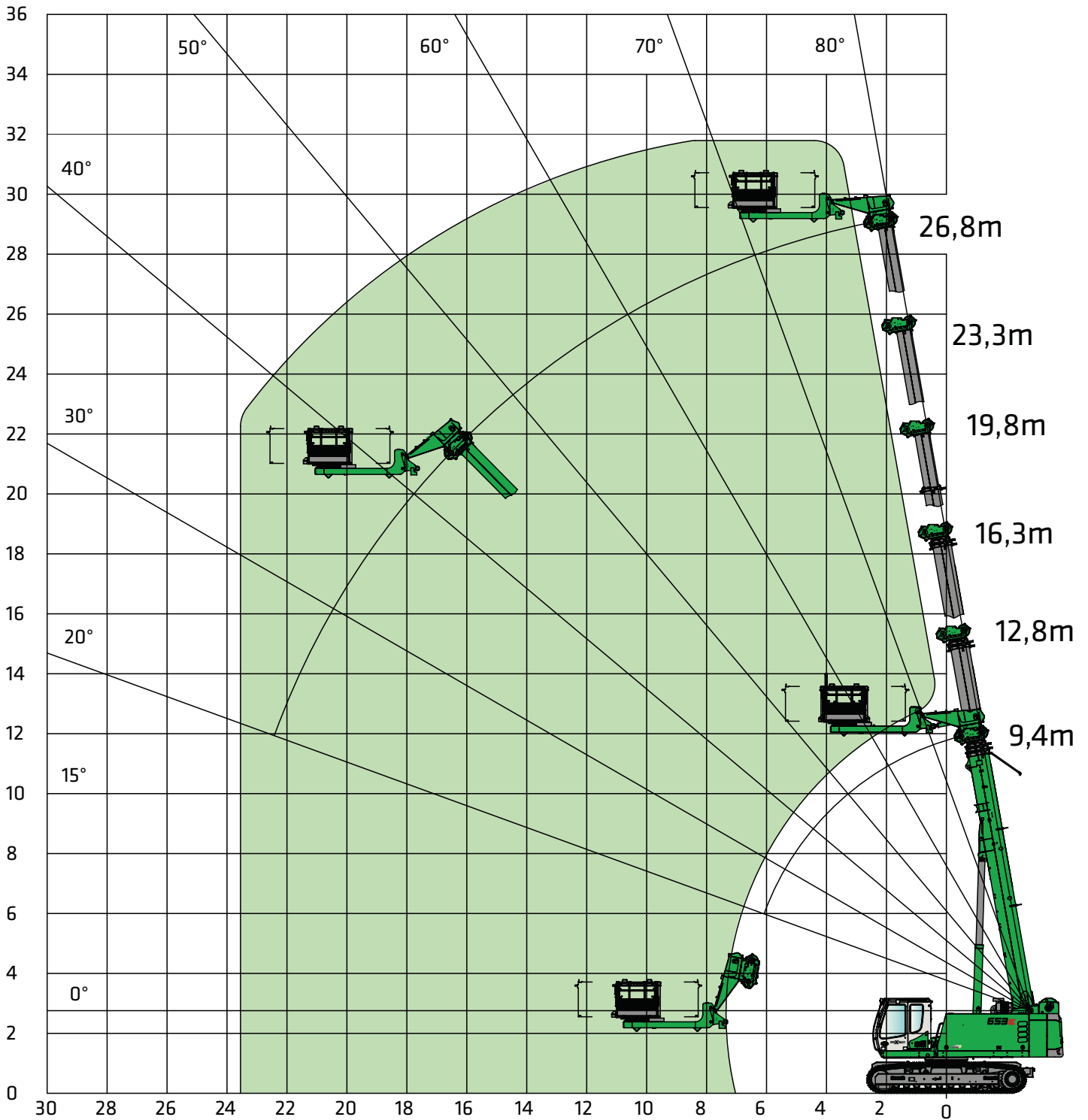

653E Load capacity programs

		Main boom (HA)			Auxiliary jib (HA-S)			6.5-m fly jib (SA)			13-m fly jib (SA)		
Counterweight [t]	Carbody counterweight [t]												
Undercarriage track width		3.8 m	3.0 m	2.3 m	3.8 m	3.0 m	2.3 m	3.8 m	3.0 m	2.3 m	3.8 m	3.0 m	2.3 m
8.9 t	5.5 t	360° 	360° 	360° 	360° 	360° 	360° 	360° 	—	—	360° 	—	—

Note:

Optional load capacities available for 2° and 4° incline positions.

1. Specified load ratings only apply when machine is level ($\pm 0.3^\circ$) and stable.
2. Load ratings are in tons (t) and apply for 360 degrees.
3. Load ratings are in accordance with EN 13000.
4. The weight of the load handling devices (e.g., hook, cable) must be subtracted from the load ratings.
5. Load ratings must be limited or reduced when conditions are unfavorable, such as soft or uneven ground, slopes, wind, lateral loads, swinging loads, jerking or sudden stopping of load, operator inexperience, driving with load.
6. Permissible cable pull per strand in crane mode for cable diameter 16 mm – 5,000 kg.
7. Specified load ratings are for reference only. See the tables in the operating manual for the applicable load rating.

653E Fly boom



Fly boom variants

- 6.5-m fly jib*
Max. 2-lines, possible offset angle 0°/40°
- 13-m fly boom* with 6.5-m extension, line offset angle 0°/40°
- Auxiliary jib, 5-t load capacity, 1-line

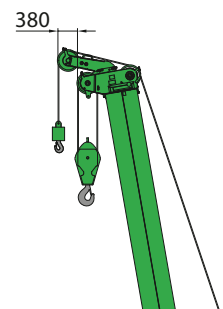
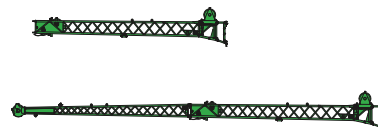

653E Transport dimensions and weights

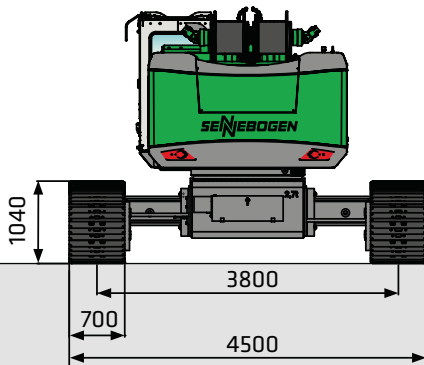

653 with T41/380 undercarriage and 700-mm 3-grouser crawler shoes

Operating weight: approx. 50,200 kg

(with 13-m fly boom, 2 hoisting winches, 8.9-t counterweight, 5.5-t undercarriage ballast and 35-t hook)

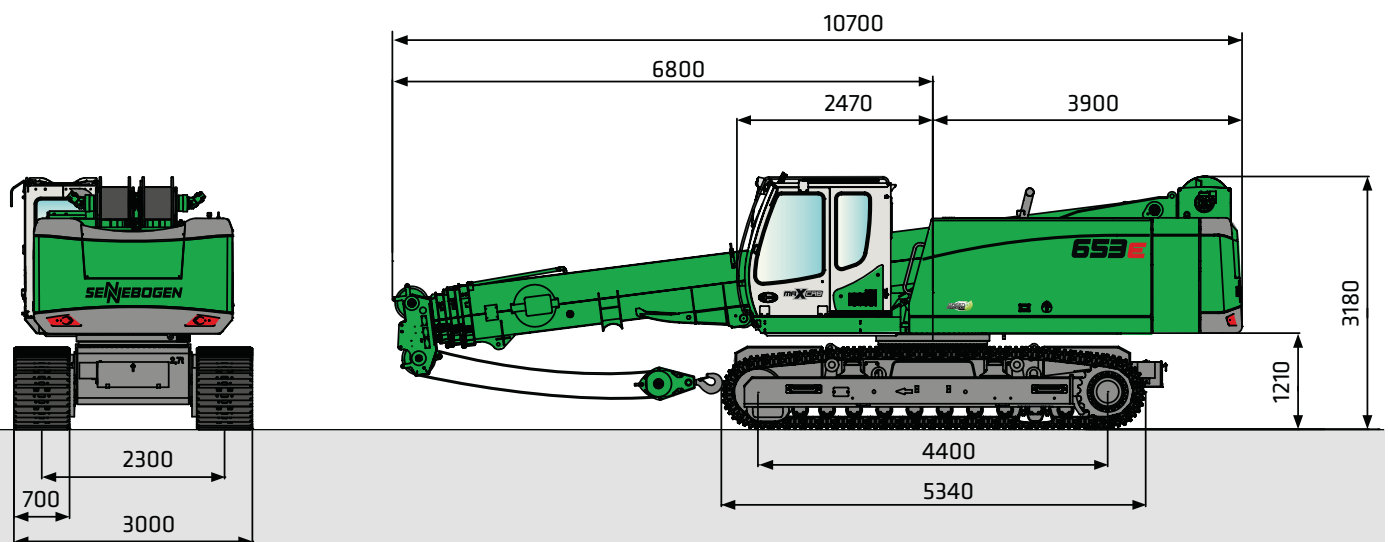

Transport weight: approx. 44,700 kg (13-m fly boom, 2 hoisting winches, without undercarriage ballast)
 approx. 50.200 kg (13-m fly boom, 2 hoisting winches, with undercarriage ballast)

653E Transport dimensions and weights

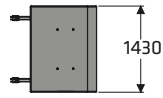
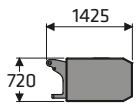

Undercarriage ballast

2x 2,750 kg

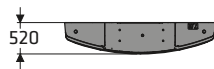
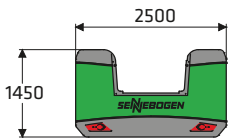

Counterweight

7,000 kg

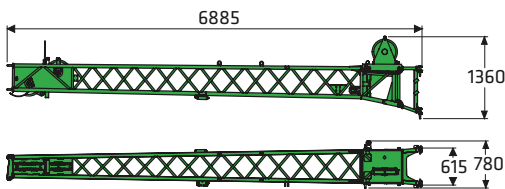

6.5-m fly boom

600 kg

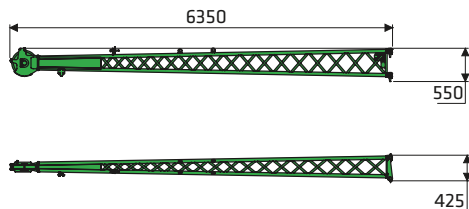

6.5-m fly boom extension

250 kg

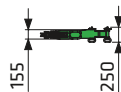
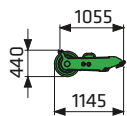

5-t auxiliary jib

50 kg

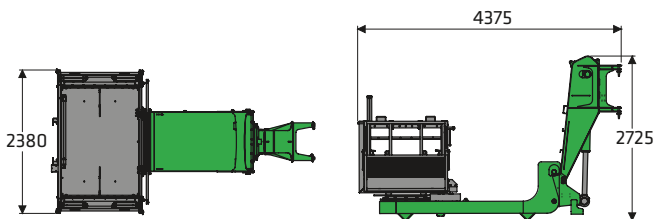

Work platform incl. adapter, width: 2.4 m

2,300 kg

653E

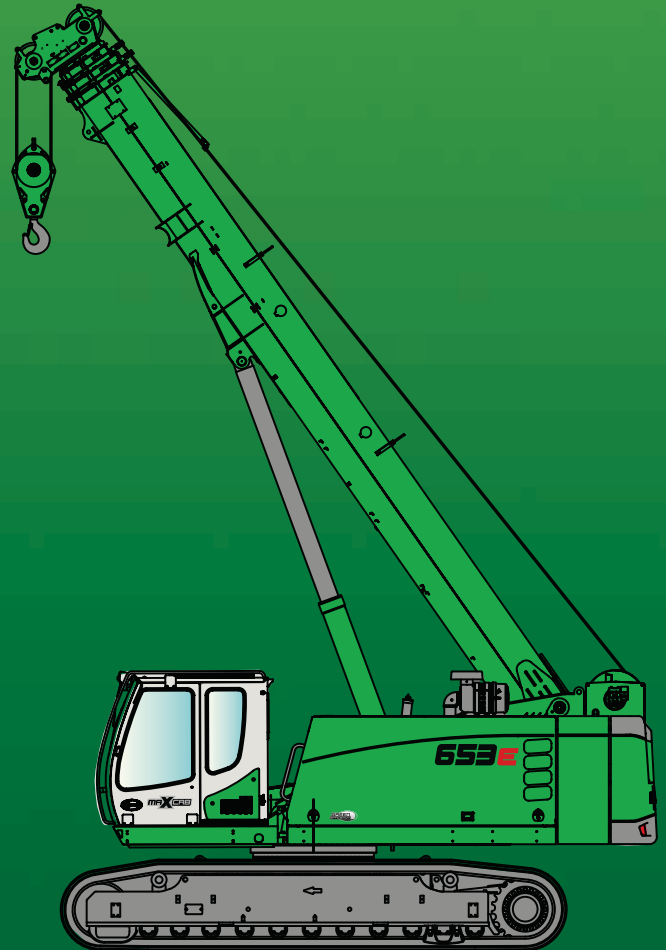

This catalog describes machine models, scope of equipment of individual models, and configuration options (standard equipment and optional equipment) of the machines delivered by SENNEBOGEN Maschinenfabrik. Machine illustrations can contain optional equipment and supplemental equipment. Actual equipment may vary depending on the country to which the machines are delivered, especially in regard to standard and optional equipment.

All product designations used may be trademarks of SENNEBOGEN Maschinenfabrik GmbH or other supplying companies, and any use by third parties for their own purposes may violate the rights of the owners.

Please contact your local SENNEBOGEN sales partner for information concerning the equipment variants offered. Requested performance characteristics are only binding if they are expressly stipulated upon conclusion of the contract. Delivery options and technical features subject to change. Errors and omissions excepted. Equipment is subject to change, and rights of advancement are reserved.

© SENNEBOGEN Maschinenfabrik GmbH, Straubing, Germany. Reproduction in whole or in part only with written consent of SENNEBOGEN Maschinenfabrik GmbH, Straubing, Germany.

SENNEBOGEN

SENNEBOGEN
Maschinenfabrik GmbH
Sennebogenstrasse 10
94315 Straubing, Germany

Tel. +49 9421 540-144/146
Fax +49 9421 43 882
marketing@sennebogen.de

Order no. / Item No. 187550
653H-D-E-0415005

GO FOR GREEN

 www.sennebogen.de